

2. PRIBOR G80 I G100 G80 and G100 accessories

2.1. Pribor G80

Očna matica G80 RX055

Eye nut G80

Nosivost na 0° (t)	Nosivost do 90° (t)	M (mm)	D (mm)	N (mm)	L (mm)	Težina (kg/ kom)
WLL 0°	WLL 90°					Weight
0,4	0,15	6	36	20	36	0,05
0,8	0,4	8	36	20	36	0,05
1,0	0,4	10	45	25	45	0,09
2,0	0,75	12	54	30	53	0,16
3,0	1,0	14	63	35	62	0,24
4,0	1,5	16	63	35	62	0,24
5,0	2,0	18	72	40	71	0,34
6,0	2,3	20	72	40	71	0,36
7,0	2,8	22	81	45	81	0,58
8,0	3,2	24	90	50	90	0,72
10	4	27	90	50	90	0,72
12	4,5	30	108	60	109	1,32

2.1 2.2 CE

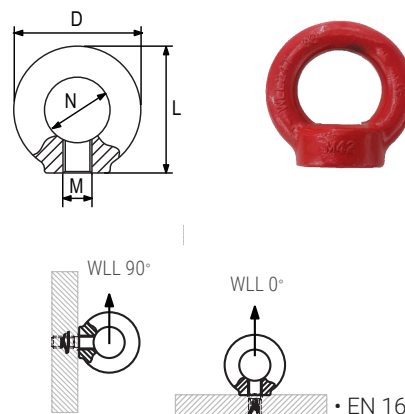

• EN 1677-1

Očni vijak G80 RX054

Eye bolt G80

Nosivost na 0° (t)	Nosivost do 90° (t)	M (mm)	D (mm)	K (mm)	N (mm)	L (mm)	Težina (kg/ kom)
WLL 0°	WLL 90°						Weight
0,4	0,15	6	28	13	16	42	0,05
0,8	0,4	8	36	15	20	51	0,06
1,0	0,4	10	45	18	25	63	0,11
20,0	0,75	12	54	22	30	75	0,18
3,0	1,0	14	63	28	35	89,5	0,28
4,0	1,5	16	63	28	35	90	0,29
5,0	2,0	18	72	30	40	101	0,42
6,0	2,3	20	72	30	40	101	0,45
7,0	2,8	22	81	34,5	45	115	0,67
8,0	3,2	24	90	38	50	128	0,87
10	4,0	27	90	38	60	128	0,88
12	4,5	30	108	45	60	154	1,66

2.1 2.2 CE

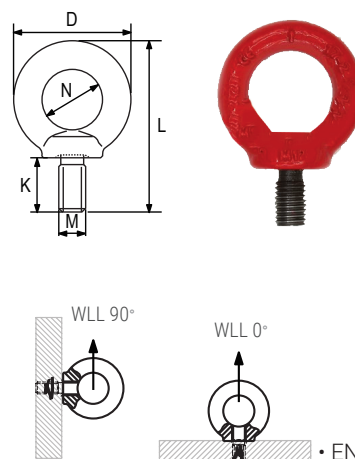

• EN 1677-1

Vijak sa okom G80 tip AL

Lifting eye type AL G80

Nosivost (t)	A (mm)	B (mm)	C (mm)	D (mm)	E (mm)	F (mm)	G (mm)	Težina (kg/ kom)
WLL								Weight
0,2	M6x1,0	20	34	20	20	17	7	0,05
0,4	M8x1,25	20	34	20	24	17	7	0,07
0,7	M10x1,5	20	38	22	30	19	8	0,08
1,0	M12x1,75	25	47	27	36	23	10	0,14
1,2	M14x2,0	30	57	30	40	27	14	0,25
1,5	M16x2,0	36	63	35	53	31	14	0,39
2,0	M18x2,5	36	63	35	53	31	14	0,38
2,5	M20x2,5	40	72	40	58	34	16	0,58
3,0	M22x2,5	42	82	45	64	38	19	1,01
4,0	M24x3,0	55	95	55	84	40	20	1,12
5,0	M27x3,0	55	95	55	84	40	20	1,18
6,0	M30x3,5	60	108	60	99	49	24	1,84 e

2.1 2.2 CE

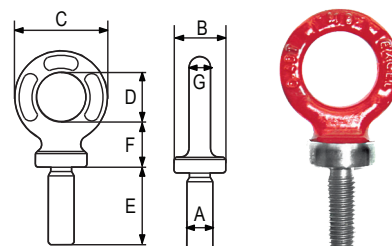

• EN 1677-1